

SERIAL Devices to PROFIBUS

SPI 3



Benefits

Integration of devices with a serial interface as DP slave devices in PROFIBUS

Available for various protocols and physical interfaces

By using the SPI 3, devices with serial interface are integrated in PROFIBUS as DP slaves. Depending on the application, various protocols and physical interfaces are available. In decentralized PROFIBUS installations, the SPI 3 replaces the serial interface inside the PLC. The SPI 3 is configured via the respective PROFIBUS DP master by means of the SPI 3 GSE file. The PROFIBUS IO range can be flexibly configured. The SPI 3 is suitable for simple applications, such as connecting text displays or barcode scanners, as well as for more complex applications such as the integration of identification systems, scales, controllers and laboratory equipment.

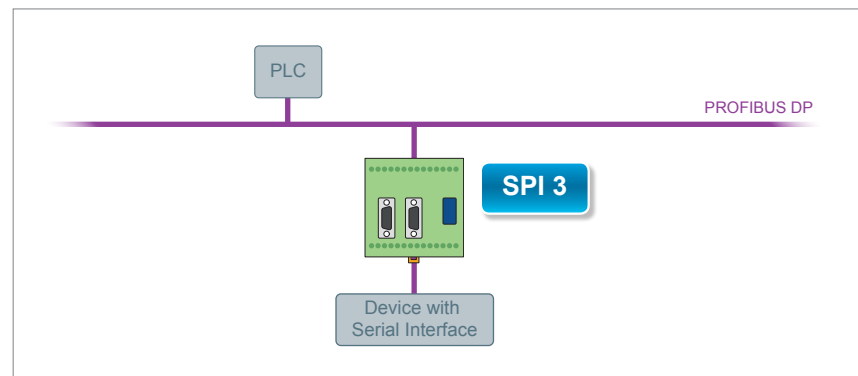

Functions

- Easy installation and parameterization
- Configuration without additional software
- Flexible configuration of PROFIBUS IO range
- DP slave with a transmission rate of 9.6 kBit/s up to 12 MBit/s
- Serial transmission rate 110 Bit/s up to 57.6 kBit/s (depending on the protocol)
- Serial interfaces RS 232, RS 422 or RS 485 available
- Configuration with GSE file via the PROFIBUS DP master
- Plug & play integration into PROFIBUS
- IO range configurable from 2 to 64 data words

Technical Data

Nominal supply voltage	24 V DC (19.2 ... 28.8)
Current consumption	max. 200 mA
Ambient temperature range	0 ... +60°C
Transmission rate serial	110 Bit/s up to 57.6 kBit/s (depending on the protocol)
Interface serial	RS 232, RS 422, RS 485 (interface as per order)
Protocols serial	Free ASCII driver, 3964R, RK512, MODBUS RTU
Transmission rate PROFIBUS	9.6 kBit/s up to 12 MBit/s
Interface PROFIBUS	RS 485
IO Range PROFIBUS	2, 4, 8, 16, 32, 64 data words (depending on the protocol)
Case, protection class	Plastic, IP 20
Mounting	35 mm DIN top hat rail
Dimensions W x H x D	75 x 75 x 53 mm
Weight	136 g
Certificate	CE, UL

Scope of Delivery

- SPI 3
- Installation Guide

By Download

- Docu + Media Kit (includes online documentation, GSE, function blocks for SIMATIC S5 and S7, example projects)
- Release Note

Order Information

- | | |
|----------------|---------------|
| • SPI 3 RS 232 | GPA-NS-011236 |
| • SPI 3 RS 422 | GPA-NS-011237 |
| • SPI 3 RS 485 | GPA-NS-011238 |

Your local contact/order here

- order.sia@softing.com
- Tel.: +49 89 456 56-340
- Fax: +49 8945656-488
- <http://industrial.softing.com/de/communication.html>

